

 **PIONEER**

Service Manual

**CIRCUIT DESCRIPTIONS
REPAIR & ADJUSTMENTS**



**ORDER NO.
ARP-296-0**

STEREO AMPLIFIER

SA-1040

MODEL SA-1040 COMES IN FOUR VERSIONS DISTINGUISHED AS FOLLOWS:

Type	Voltage	Remarks
KU	AC120V only	U.S.A. model
S	AC110V, 120V, 220V, 240V (switchable)	General export model
S/G	AC110V, 120V, 220V, 240V (switchable)	U.S. Military model
YP	AC240V only	Australia model

- This service manual is applicable to the KU type. For servicing of the other types, please refer to the pp. 25 – 26.
- Ce manuel d'instruction se réfère au mode de réglage, en français.
- Este manual de servicio trata del método de ajuste escrito en español.

CONTENTS

1. SPECIFICATIONS	2	7. SCHEMATIC DIAGRAM	15
2. FRONT PANEL FACILITIES	3	8. ELECTRICAL PARTS LIST	18
3. PARTS LOCATION	5	9. PACKING	20
4. EXPLODED VIEW	7	10. SAFETY INFORMATION	21
5. BLOCK DIAGRAM	9	11. FOR S AND S/G TYPES	22
6. P.C. BOARDS CONNECTION DIAGRAM	11	12. FOR YP TYPE	23

PIONEER ELECTRONIC CORPORATION 4-1, Meguro 1-Chome, Meguro-ku, Tokyo 153, Japan
PIONEER ELECTRONICS [USA] INC. 1925 E. Dominguez St., Long Beach, California 90810 U.S.A.
PIONEER ELECTRONIC [EUROPE] N.V. Keetberglaan 1, 2740 Beveren, Belgium
PIONEER ELECTRONICS AUSTRALIA PTY. LTD. 178-184 Boundary Road, Braeside, Victoria 3195, Australia

1. SPECIFICATIONS

Amplifier Section

Continuous Average Power Output is 100 watts* per channel, min., at 8 ohms from 20 Hertz to 20,000 Hertz with no more than 0.009% total harmonic distortion.

Total Harmonic Distortion (20 Hertz to 20,000 Hertz, 8 ohms, from CD/AUX)

continuous rated power output No more than 0.009%
100 watts per channel power output

..... No more than 0.009%

Intermodulation Distortion (50 Hertz:7,000 Hertz = 4:1, 8 ohms, from CD/AUX)

continuous rated power output No more than 0.02%

Damping Factor

(1,000 Hertz, 8 ohms) 70

(20 Hertz to 20,000 Hertz, 8 ohms) 60

Input (Sensitivity/Impedance)

PHONO 2.5 mV/50 kilohms

TUNER, CD/AUX, TAPE PLAY, ADAPTOR IN

..... 150 mV/50 kilohms

Phono Overload Level (T.H.D. 0.1%, 1,000 Hz)

PHONO 200 mV

Output (Level)

TAPE REC, ADAPTOR OUT 150 mV

Speaker 6 — 16 Ω

Frequency Response

PHONO (RIAA Equalization)

..... 20 Hz to 20,000 Hz ± 0.2 dB

TUNER, CD/AUX, TAPE PLAY, ADAPTOR

..... 10 Hz to 100,000 Hz ± 3 dB

Tone Control

BASS ± 10 dB (100 Hz)

TREBLE ± 10 dB (10 kHz)

Subsonic Filter 15 Hz (-3 dB/oct.)

Loudness Contour (Volume control set at -40 dB position)

..... $+6$ dB (100 Hz), $+3$ dB (10 kHz)

Hum and Noise (IHF, short circuited A network)

PHONO 86 dB

TUNER, CD/AUX, TAPE PLAY, ADAPTOR IN

..... 106 dB

Miscellaneous

Power Requirements

KU, KC models AC 120 Volts, 60 Hz

S, S/G models

..... \sim AC 110 V/120 V/220 V/240 V (switchable) 50/60 Hz

YP model a.c. 240 Volts \sim , 50 Hz

Power Consumption

KU, KC models 170 Watts (max.)

S, S/G models 230 Watts (max.)

YP model 700 Watts (max.)

Dimensions 420 (W) x 98 (H) x 327 (D) mm

16-9/16 (W) x 3-7/8 (H) x 12-7/8 (D) in

Weight (without package) 8.2 kg (18 lb 1 oz)

Furnished Parts

Operating Instructions 1

*Measured pursuant to the Federal Trade Commission's Trade Regulation rule on Power Output Claims for Amplifier.

NOTE:

Specifications and design subject to possible modifications without notice.

2. FRONT PANEL FACILITIES

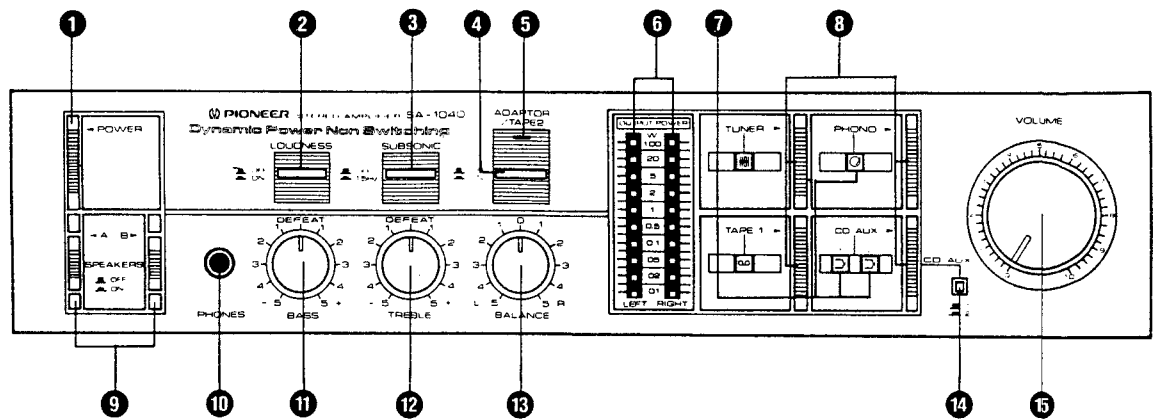

1 POWER SWITCH

When this switch is pressed, the power is supplied (the function indicators light). When it is pushed again, the power is switched off.

2 LOUDNESS SWITCH

Push this switch to the "ON" position for low-volume sound listening. The bass and treble are emphasized and you can sit back and listen to a dynamic sound even under low-volume conditions.

3 SUBSONIC FILTER SWITCH

The subsonic filter with the 15 Hz cutoff frequency is actuated when this switch is depressed to the 15 Hz (ON) position (the SUBSONIC indicator lights).

This filter serves to attenuate frequencies lower than 15 Hz with a 6 dB/oct slope and, therefore, it can be used to suppress the ultra-low-range noise which is generated by record warp and other factors. This noise cannot actually be heard by the ear but it can cause cross modulation distortion and even speaker damage. Use this switch when required during record play.

4 ADAPTOR/TAPE 2 SWITCH

This is used when operating an adaptor (such as a tape creating amplifier) or when playing back a tape in a tape deck connected to the rear panel ADAPTOR/TAPE 2 terminals.

5 ADAPTOR/TAPE 2 INDICATOR

This lights when the ADAPTOR/TAPE 2 switch is set to ON.

6 OUTPUT POWER INDICATORS

The left and right indicators show the output level (in watts) when a speaker system with an 8-ohm nominal impedance has been connected to the unit. "L" indicates the left channel output level and "R" the right channel.

7 FUNCTION INDICATORS

The indicator corresponding to the function switch which has been pushed lights. Each indicator has a symbol: "⊙" for PHONO, "⊞" for TUNER, "≡" for CD/AUX and "∞" for TAPE 1.

8 FUNCTION SWITCHES

PHONO: Used when playing records on a turntable connected to the rear panel PHONO terminals.

TUNER: Used when listening to broadcasts on the tuner connected to the rear panel TUNER terminals.

CD/AUX: Used when operating a TV tuner or compact disc player etc. connected to the rear panel CD/AUX terminals.

TAPE 1: Used when playing back tapes on the tape deck connected to the rear panel TAPE 1 terminals.

9 SPEAKER SELECTOR SWITCHES

Select the switch that corresponds to the speaker systems through which the sound is to be heard. When the switch is pressed, the sound is heard through the speaker systems selected.

A: The sound is heard from the speakers connected to the speaker A terminals on the rear panel.

B: The sound is heard from the speakers connected to the speaker B terminals on the rear panel.

No sound will be heard when SPEAKERS A and B switches are both released. This is the position at which the sound can be heard through the headphones.

NOTE:

No sound will be heard through the speakers when both the A and B switches are depressed if only one set of speakers has been connected to either the A or B SPEAKERS terminals.

10 PHONES JACK

Plug the headphones into this jack securely for private listening.

NOTE:

Make it a rule to turn down the volume before plugging in the headphones. A loud sound can hurt your ears.

11 BASS CONTROL

This is used to adjust the bass sound.

When rotated clockwise from the center DEFEAT position, the bass is emphasized; when rotated counterclockwise, the bass is attenuated.

12 TREBLE CONTROL

This is used to adjust the treble sound.

When rotated clockwise from the center DEFEAT position, the treble is emphasized; when rotated counterclockwise, the treble is attenuated.

13 BALANCE CONTROL

This is normally kept at the "0" position. It should be adjusted when the left/right stereo balance has become lopsided. Rotate the control to the left when the right channel sound is too loud; rotate it to the right when the left channel sound is too loud.

14 CD/AUX 1, 2 SELECTOR SWITCH

Use this to select the component which has been connected to the auxiliary (CD/AUX 1, 2) terminals on the rear panel.

15 VOLUME CONTROL

This is used to adjust the sound volume of the speakers and headphone. No sound will be heard when the control has been set to the "0" position. Rotate the control clockwise to increase the sound level.

3. PARTS LOCATION

NOTES:

- Parts without part number cannot be supplied.
- The Δ mark found on some component parts indicates the importance of the safety factor of the part. Therefore, when replacing, be sure to use parts of identical designation.
- For your Parts Stock Control, the fast moving items are indicated with the marks **★★** and **★**.
★★ GENERALLY MOVES FASTER THAN ★.
 This classification shall be adjusted by each distributor because it depends on model number, temperature, humidity, etc.

Front Panel View

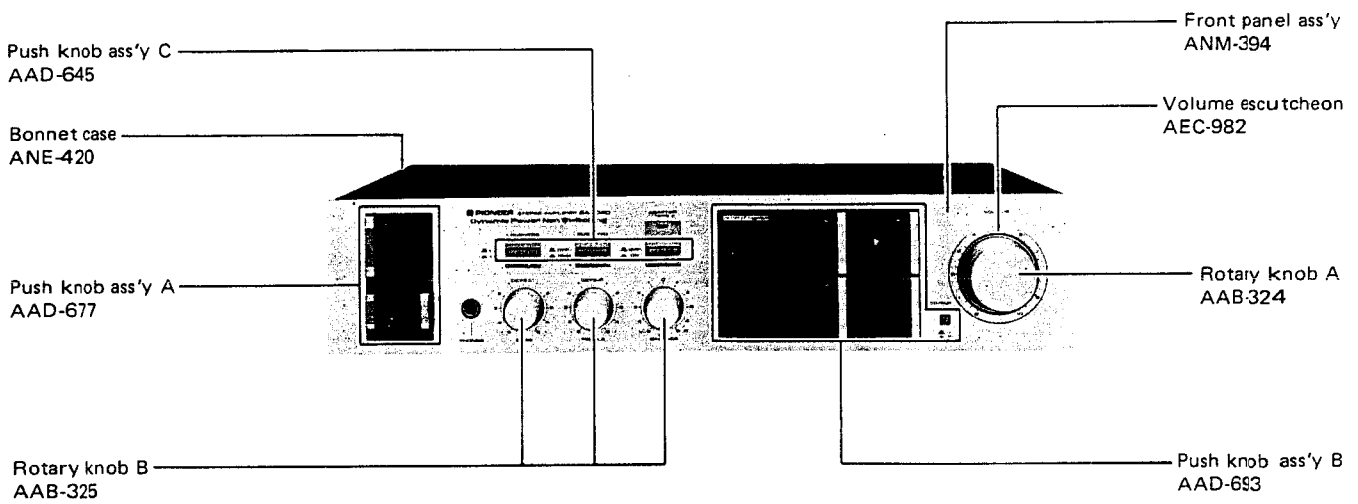

Front View with Panel Removed

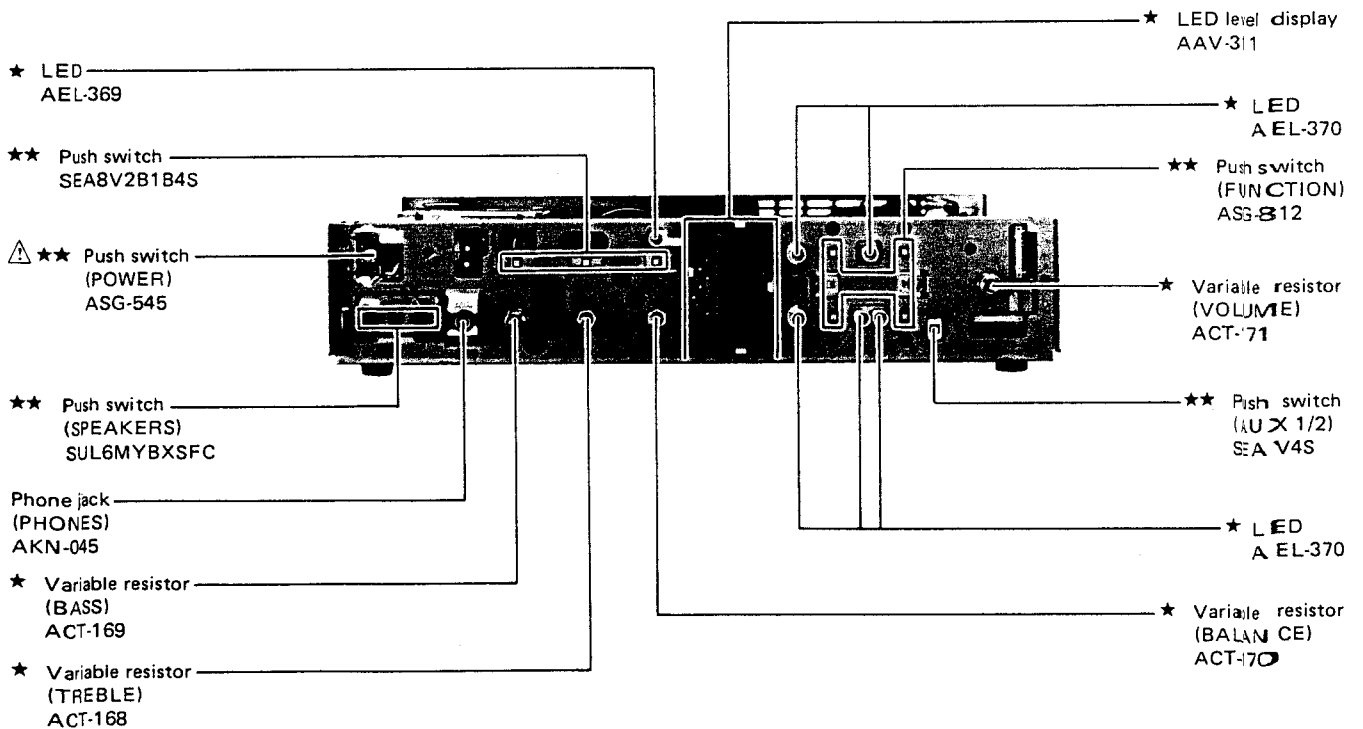

Top View

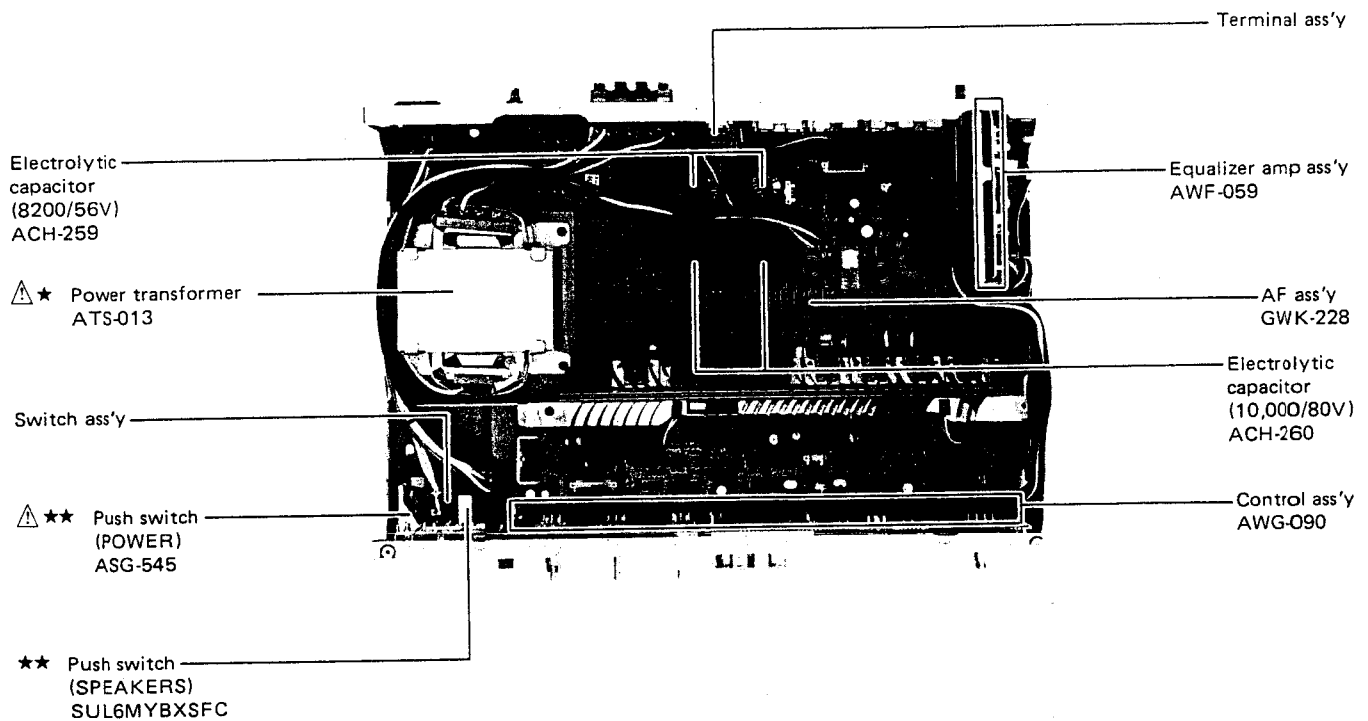

Rear Panel View

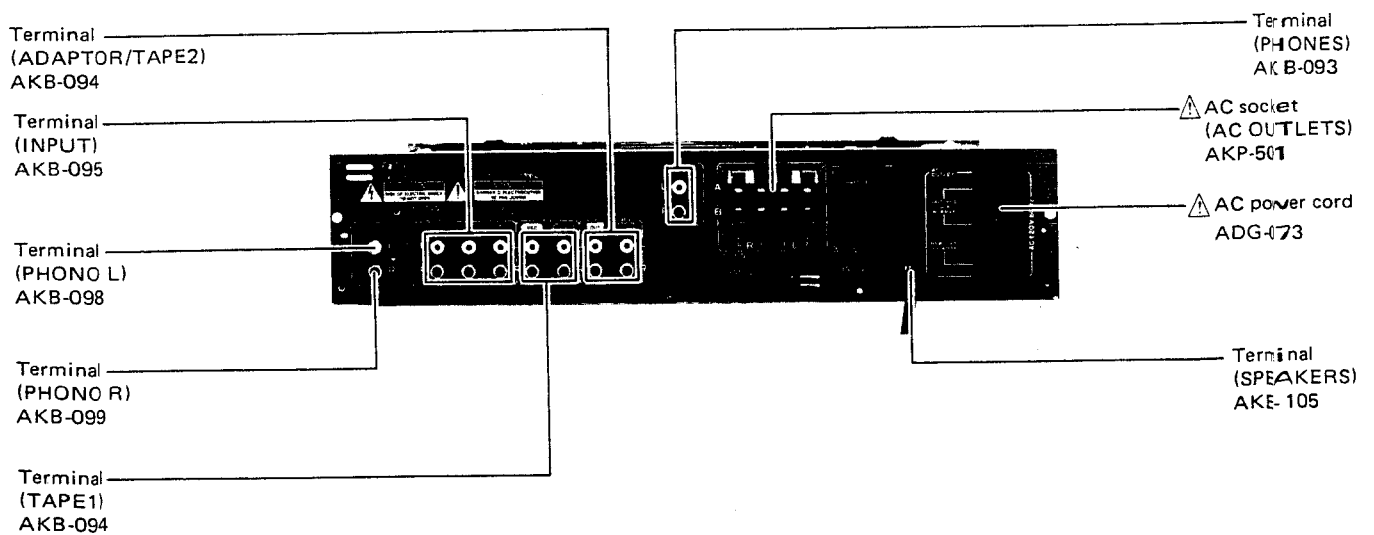

4. EXPLODED VIEW

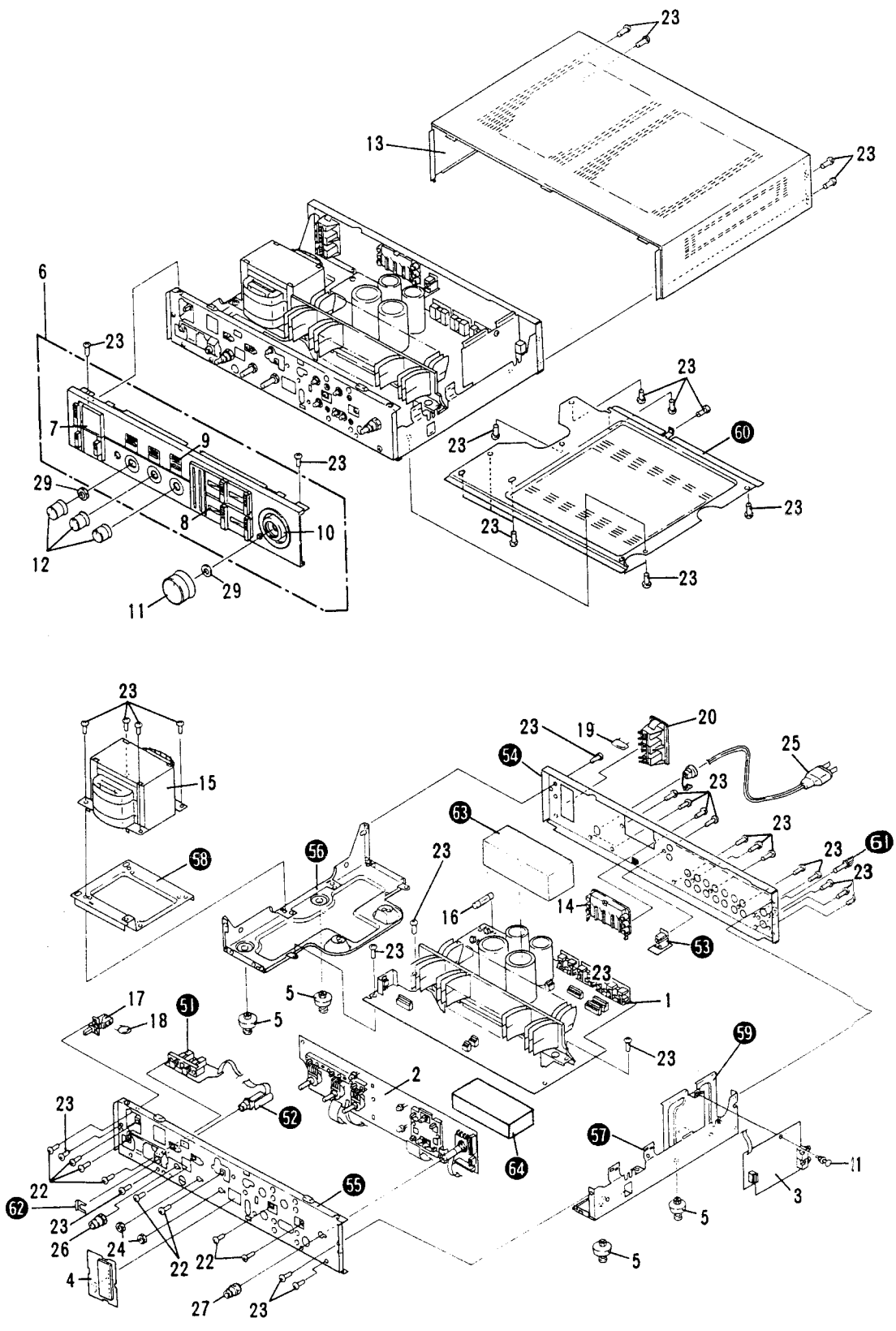

NOTES:

- Parts without part number cannot be supplied.
- The \triangle mark found on some component parts indicates the importance of the safety factor of the part. Therefore, when replacing, be sure to use parts of identical designation.
- For your Parts Stock Control, the fast moving items are indicated with the marks **★★** and **★**.
★★ GENERALLY MOVES FASTER THAN ★.
 This classification shall be adjusted by each distributor because it depends on model number, temperature, humidity, etc.

Mark	No.	Part No.	Description
	1.	GWK-228	AF ass'y
	2.	AWG-090	Control ass'y
	3.	AWF-059	Equalizer amp ass'y
★	4.	AAV-311	LED level display
	5.	AEC-847	Leg ass'y
	6.	ANM-394	Front panel ass'y
	7.	AAD-677	Push knob ass'y A
	8.	AAD-693	Push knob ass'y B
	9.	AAD-645	Push knob ass'y C
	10.	AEC-982	Volume escutcheon
	11.	AAB-324	Rotary knob A
	12.	AAB-325	Rotary knob B
	13.	ANE-420	Bonnet case
	14.	AKE-105	Terminal (SPEAKERS)
\triangle ★	15.	ATS-013	Power transformer
\triangle ★★	16.	AEK-309	Fuse (6.3A)
\triangle ★★	17.	ASG-545	Push switch (POWER)
\triangle	18.	ACG-502	Ceramic capacitor
\triangle	19.	ACE-214	Ceramic capacitor
\triangle	20.	AKP-501	AC socket (AC OUTLETS)
	21.	AEC-510	Nylon rivet
	22.	PMZ30P060FMC	Screw (3x6)
	23.	BBZ30P080FZK	Screw (3x8)
	24.	NK70FUC	Nut
\triangle	25.	ADG-073	AC power cord
	26.	ABN-075	Guide nut B
	27.	ABN-074	Guide nut A
	28.	AEC-471	Nylon rivet
	29.	NKX1FUC	Nut
	51.		Switch ass'y
	52.		Headphone jack ass'y
	53.		Terminal ass'y
	54.		Rear panel
	55.		Panel stay
	56.		Frame
	57.		Right frame
	58.		Stay
	59.		Shield case
	60.		Bottom plate
	61.		Terminal (GND)
	62.		Mounting plate
	63.		Cushion A
	64.		Cushion B

5. BLOCK DIAGRAM

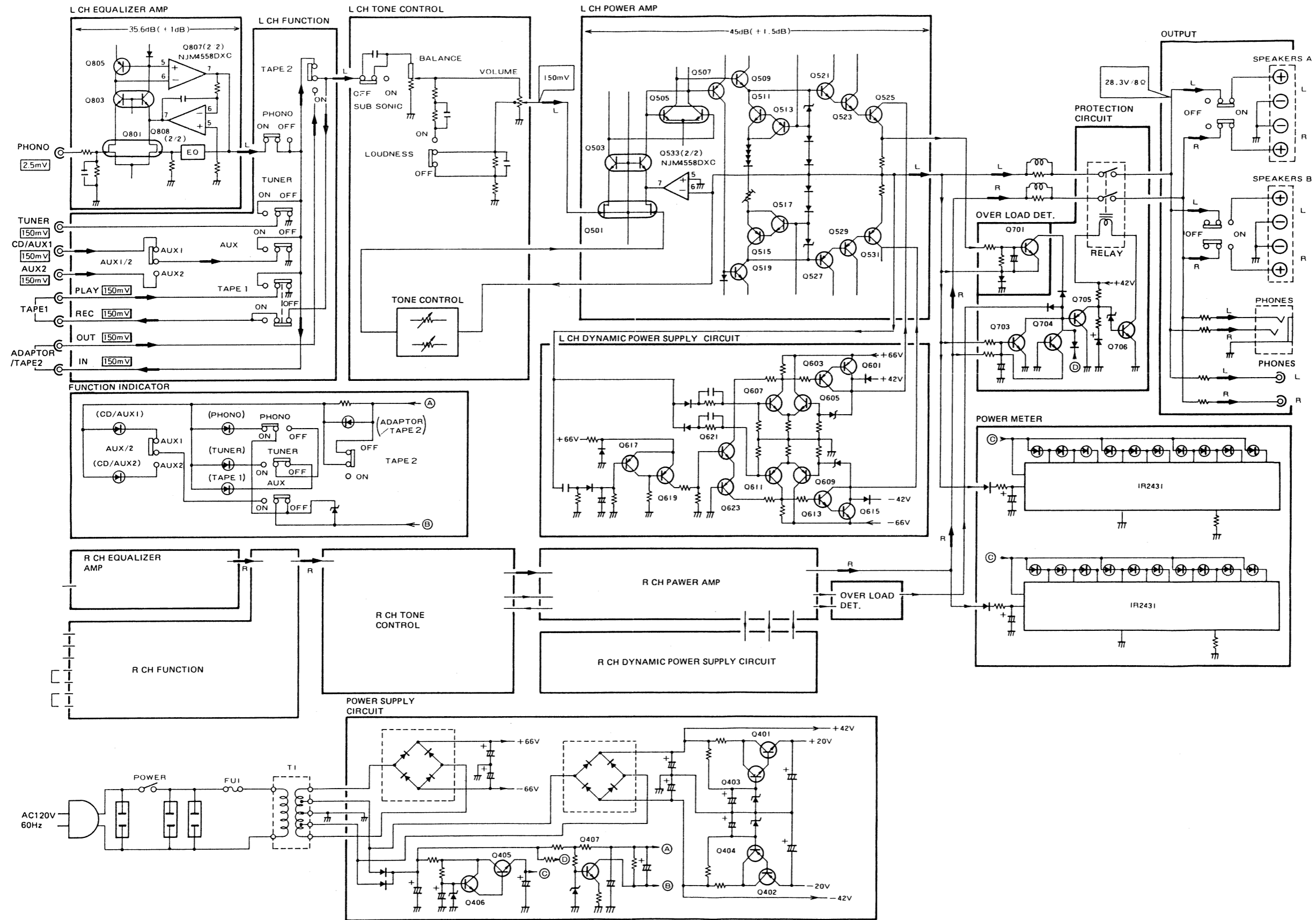

6.P.C. BOARDS CONNECTION DIAGRAM

A

B

CONTROL Ass'y AWG-090

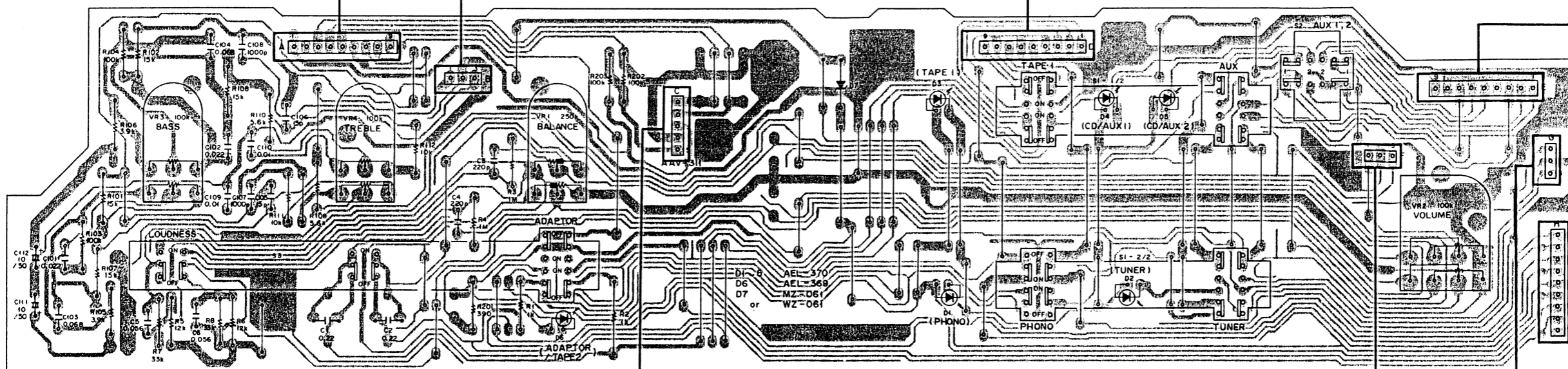

C

D

LED POWER METER AAV-311

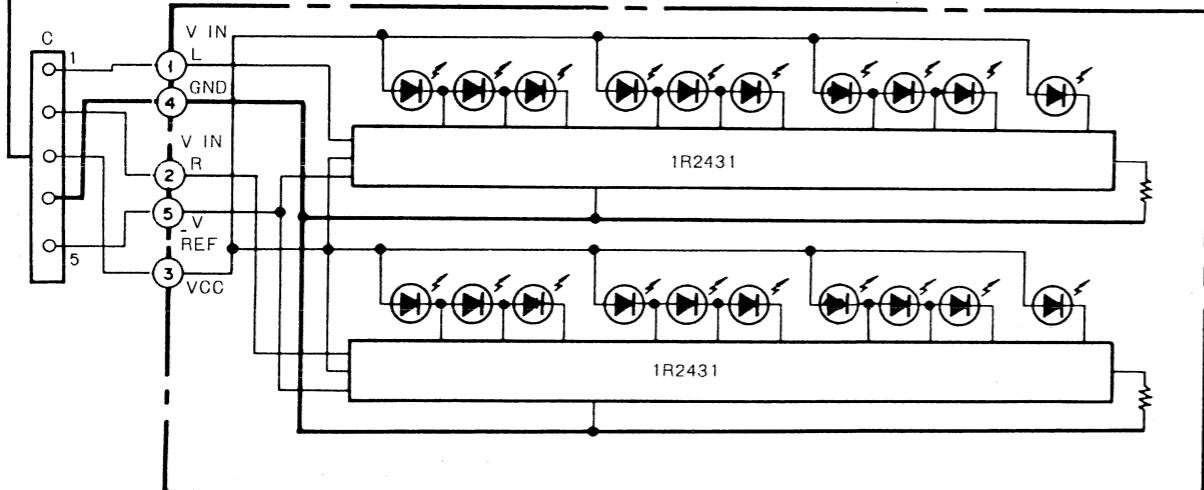

EQUALIZER Ass'y AWF-059

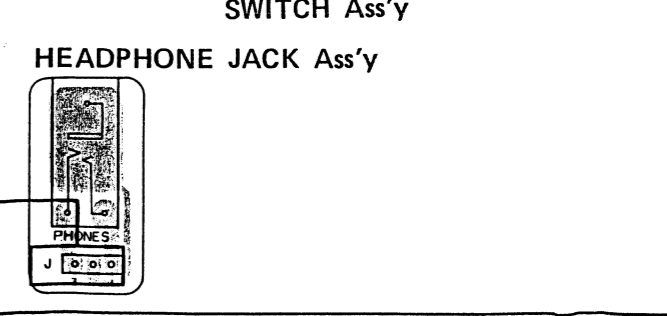
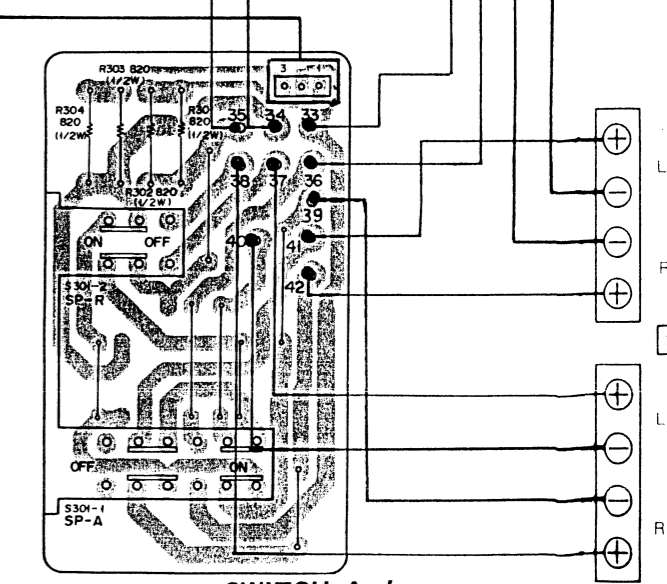
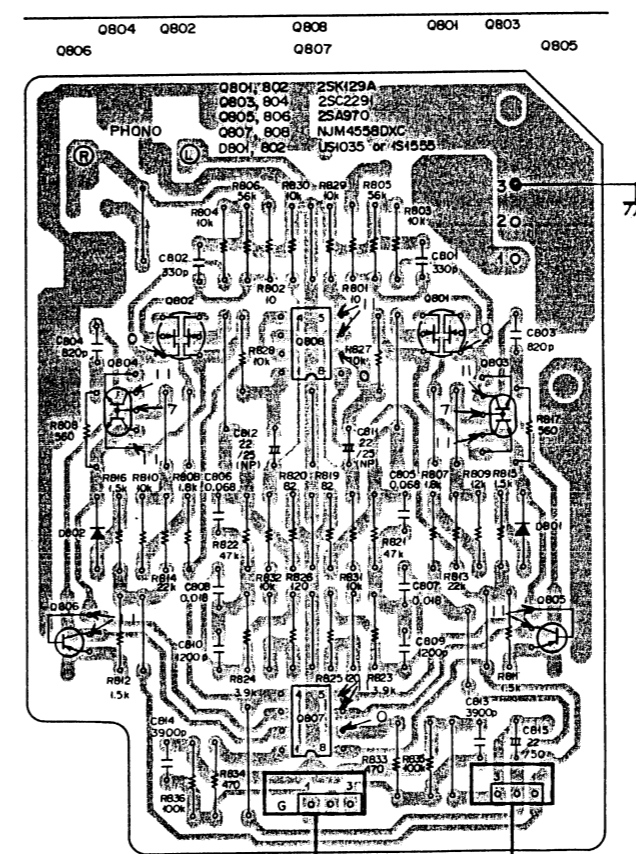

7

8

9

10

11

12

AF Ass'y GWK-228

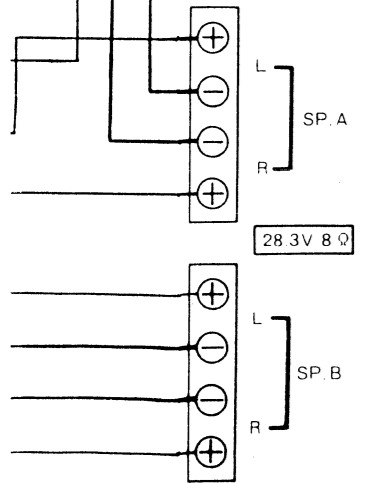
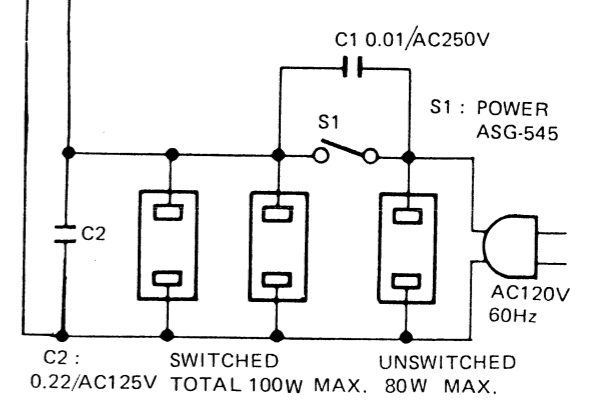
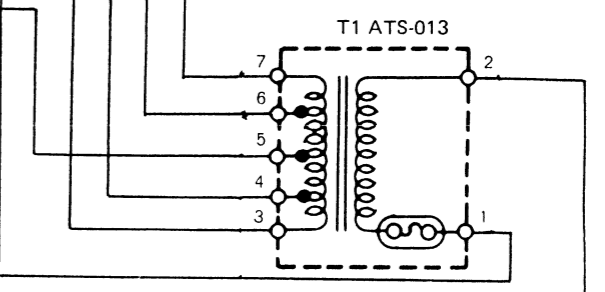
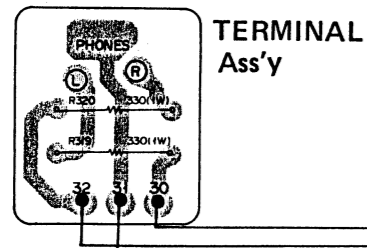
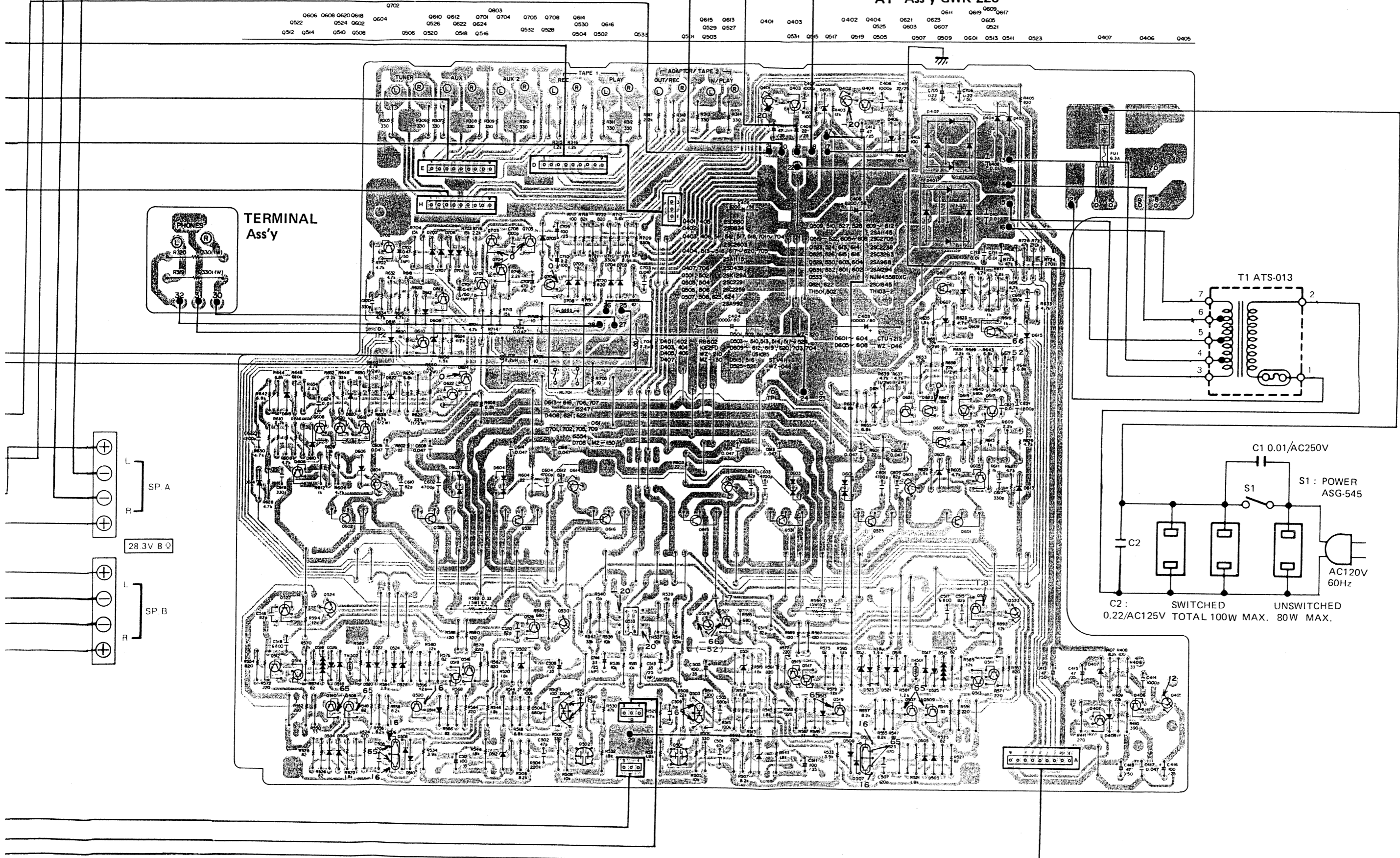

7

8

9

10

11

12

7. SCHEMATIC DIAGRAM

1

2

3

4

5

6

A

B

C

D

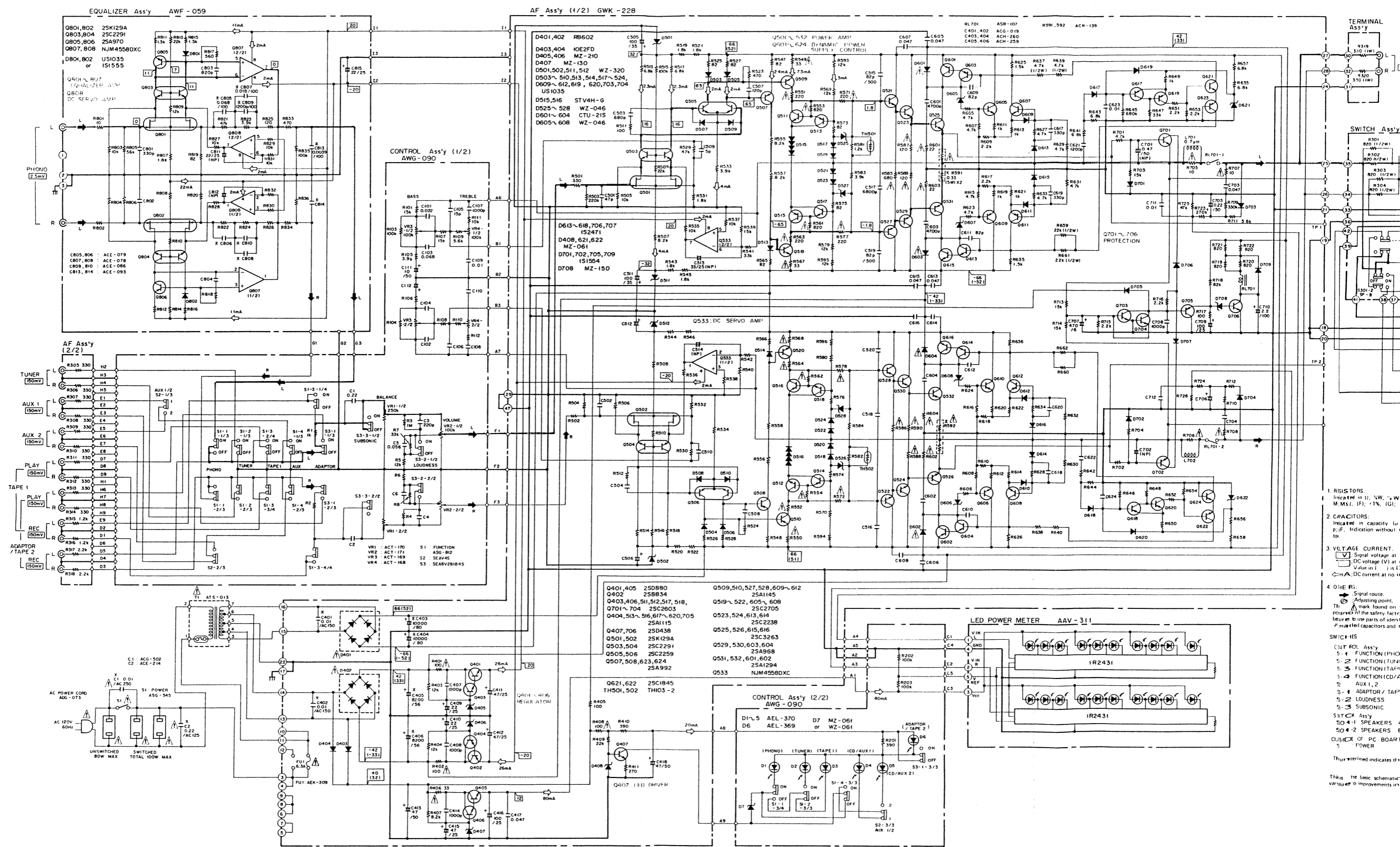

1. RESISTORS:
Indicated in Ω, kΩ, MΩ, GΩ.
M.M.S.I. (F): 1%, 5%, 10%.

2. CAPACITORS:
Indicated in pF, nF, μF.
p.F. Indication without v
for.

3. VOLTAGE CURRENT:
Signal voltage at in
DC voltage (V) at in
Value in 1.5A
DC current at in

4. DIODES:
Signal route.
Adjusting point.
Thermistor found on s
part of the safety facto
ture. Be sure parts of safety
factor capacitors and re

SWITCHES

CONTROL Ass'y
S1-1 FUNCTION (PHONO)
S1-2 FUNCTION (TUNER)
S1-3 FUNCTION (TAPE)
S1-4 FUNCTION (CD/A)
S1-5 AUX 1, 2
S1-6 ADAPTOR / TAPE
S1-7 LOUDNESS
S1-8 SUBSONIC

SWITCH Ass'y
S1-1-1 SPEAKERS A
S1-1-2 SPEAKERS B
S1-1-3 POWER

This is the basic schematic.
Various improvements in

(1/2) GWK-228

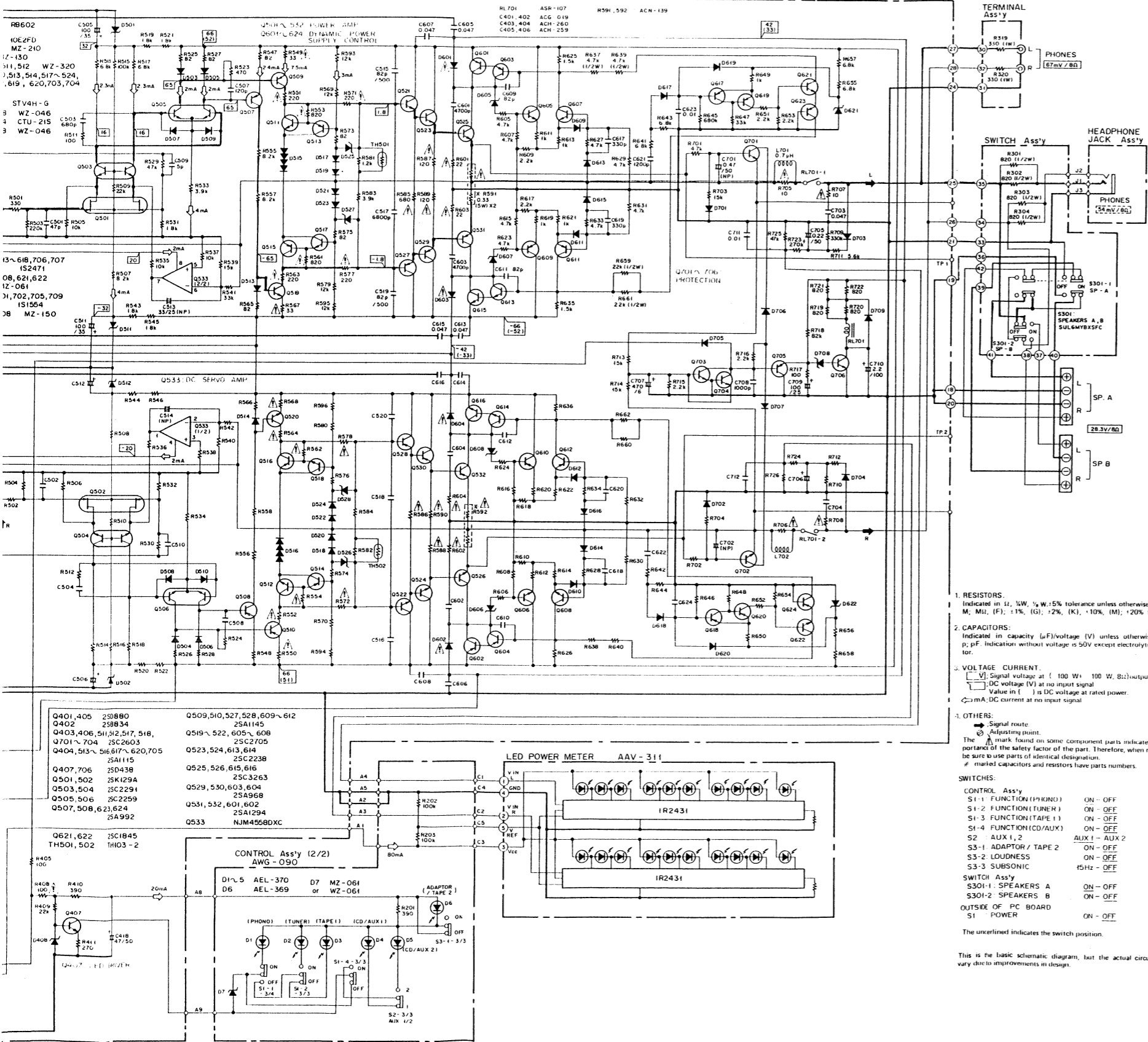

Q401,405 2S8880	Q509,510,527,528,609~612
Q402 2S8834	2SA1145
Q403,406,511,512,517,518, 519,524,525,526,527,528,529,530,603,604	2SC2705
Q404,513~516,517~524, 525,526,527,528,529,530,603,604	2SC2238
Q407,706 2SD438	Q525,526,615,616
Q501,502 2SK129A	2SC3263
Q503,504 2SC2291	Q529,530,603,604
Q505,506 2SC2259	2SA968
Q507,508,623,624	Q531,532,601,602
2SA992	2SA1294
	Q533 NJM4558DCX

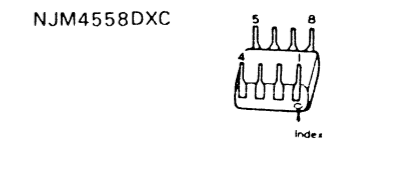
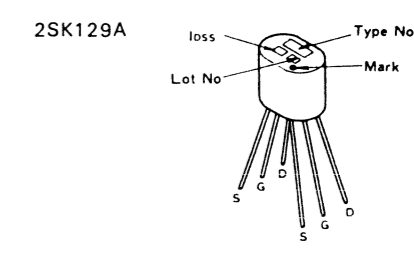
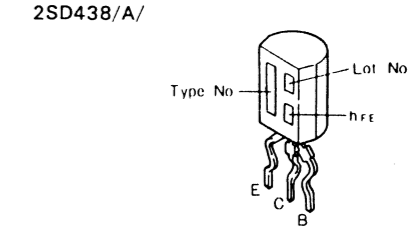
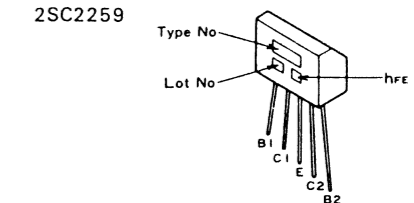
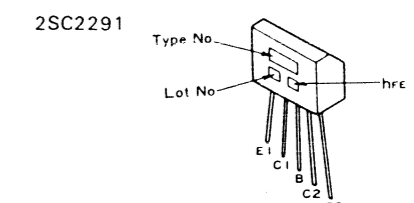
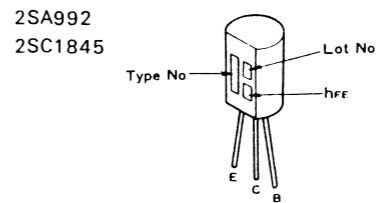
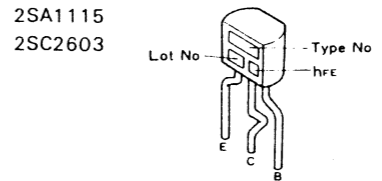
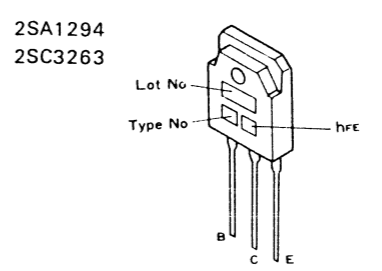
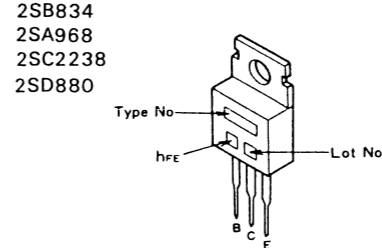
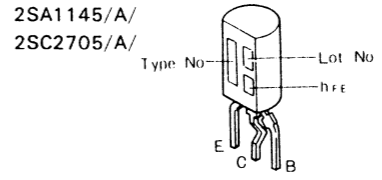
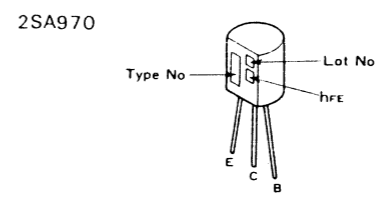
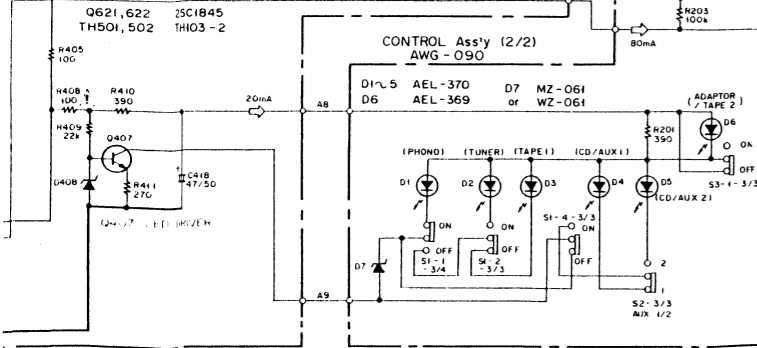

- RESISTORS:** Indicated in Ω, kΩ, MΩ, 1/2W, 1/4W, 1/8W, 5% tolerance unless otherwise noted; k, M, MΩ, (F), 1%, (G), 12%, (K), 10%, (M), 120% tolerance.
 - CAPACITORS:** Indicated in capacity (μF)/voltage (V) unless otherwise noted; p, nF. Indication without voltage is 50V except electrolytic capacitor.
 - VOLTAGE CURRENT:** [V] Signal voltage at (100 W, 100 W, 8Ω) output (1kHz); [DC] DC voltage (V) at no input signal; Value in () is DC voltage at rated power; [mA] DC current at no input signal.
 - OTHERS:**
 - Signal route
 - ↻ Adjusting point
- The mark found on some component parts indicates the importance of the safety factor of the part. Therefore, when replacing, be sure to use parts of identical designation. * marked capacitors and resistors have parts numbers.
- SWITCHES:**
- | | |
|------------------------|---------------|
| CONTROL Ass'y | ON - OFF |
| S1-1 FUNCTION (PHONE) | ON - OFF |
| S1-2 FUNCTION (TUNER) | ON - OFF |
| S1-3 FUNCTION (TAPE 1) | ON - OFF |
| S1-4 FUNCTION (CD/AUX) | ON - OFF |
| S2 AUX 1, 2 | AUX 1 - AUX 2 |
| S3-1 ADAPTOR / TAPE 2 | ON - OFF |
| S3-2 LOUDNESS | ON - OFF |
| S3-3 SUBSONIC | 15Hz - OFF |
| SWITCH Ass'y | ON - OFF |
| S301-1 SPEAKERS A | ON - OFF |
| S301-2 SPEAKERS B | ON - OFF |
| OUTSIDE OF PC BOARD | ON - OFF |
| S1 POWER | ON - OFF |
- The underlined indicates the switch position.
- This is the basic schematic diagram, but the actual circuit may vary due to improvements in design.

A

B

C

D

8. ELECTRICAL PARTS LIST

NOTES:

- When ordering resistors, first convert resistance values into code form as shown in the following examples.

Ex. 1 When there are 2 effective digits (any digit apart from 0), such as 560 ohm and 47k ohm (tolerance is shown by J = 5%, and K = 10%).

560Ω	56 × 10 ¹	561	RD¼PS	561J
47kΩ	47 × 10 ³	473	RD¼PS	473J
0.5Ω	0R5		RN2H	0R5K
1Ω	010		RS1P	010K

Ex. 2 When there are 3 effective digits (such as in high precision metal film resistors).

5.62kΩ	562 × 100	5621	RN¼SR	5621F
--------	-----------	------	-------	-------

- The Δ mark found on some component parts indicates the importance of the safety factor of the part. Therefore, when replacing, be sure to use parts of identical designation.
- For your Parts Stock Control, the fast moving items are indicated with the marks **★★** and **★**.
★★ GENERALLY MOVES FASTER THAN ★.
 This classification shall be adjusted by each distributor because it depends on model number, temperature, humidity, etc.

Miscellaneous Parts

Mark	Part No.	Symbol & Description	Mark	Part No.	Symbol & Description
				2SC2705/A/- O	Q605-Q608
				(2SC2705/A/-Y)	
				2SA1145/A/- O	Q609-Q612
				(2SA1145/A/-Y)	
				2SC2238- O	Q523, Q524, Q613, Q614
				(2SC2238-Y)	
				2SA968- O	Q529, Q530, Q603, Q604
				(2SA968-Y)	
				2SC3263- O	Q525, Q526, Q615, Q616
				(2SC3263-Y)	
				2SA1294- O	Q531, Q532, Q601, Q602
				(2SA1294-Y)	
				2SD438/A/	Q407, Q706
				2SD880	Q401, Q405
				2SB834	Q402
				NJM4558DXC	Q533
				2SC1845	Q621, Q622, Q701, Q702
				2SA992	Q507, Q508, Q623, Q624
				2SC2603	Q511, Q512, Q517, Q518
				2SA1115	Q513-Q516, Q617-Q620
				2SC2603	Q403, Q406, Q703, Q704
				RB602	D401, D402
				10E2FD	D403, D404
				CTU-21S	D601-D604
				STV4H-G	D515, D516
				TH103-2	TH501, TH502
				WZ-046	D525-D528, D605-D608
				MZ-061	D408, D621, D622
				MZ-130	D407
				MZ-150	D708
				MZ-210	D405, D406
				WZ-320	D501, D502, D511, D512
				US1035	D503-D510, D513, D514, D515, D516, D517, D518, D519, D520, D521, D522, D523, D524, D601, D602, D603, D604, D605, D606, D607, D608, D609, D610, D611, D612, D613, D614, D615, D616, D617, D618, D619, D620, D621, D622, D623, D624, D625, D626, D627, D628, D629, D630, D631, D632, D633, D634, D635, D636, D637, D638, D639, D640, D641, D642, D643, D644, D645, D646, D647, D648, D649, D650, D651, D652, D653, D654, D655, D656, D657, D658, D659, D660, D661, D662, D663, D664, D665, D666, D667, D668, D669, D670, D671, D672, D673, D674, D675, D676, D677, D678, D679, D680, D681, D682, D683, D684, D685, D686, D687, D688, D689, D690, D691, D692, D693, D694, D695, D696, D697, D698, D699, D700, D701, D702, D703, D704, D705, D706, D707, D708, D709, D710, D711, D712, D713, D714, D715, D716, D717, D718, D719, D720, D721, D722, D723, D724, D725, D726, D727, D728, D729, D730, D731, D732, D733, D734, D735, D736, D737, D738, D739, D740, D741, D742, D743, D744, D745, D746, D747, D748, D749, D750, D751, D752, D753, D754, D755, D756, D757, D758, D759, D760, D761, D762, D763, D764, D765, D766, D767, D768, D769, D770, D771, D772, D773, D774, D775, D776, D777, D778, D779, D780, D781, D782, D783, D784, D785, D786, D787, D788, D789, D790, D791, D792, D793, D794, D795, D796, D797, D798, D799, D800, D801, D802, D803, D804, D805, D806, D807, D808, D809, D810, D811, D812, D813, D814, D815, D816, D817, D818, D819, D820, D821, D822, D823, D824, D825, D826, D827, D828, D829, D830, D831, D832, D833, D834, D835, D836, D837, D838, D839, D840, D841, D842, D843, D844, D845, D846, D847, D848, D849, D850, D851, D852, D853, D854, D855, D856, D857, D858, D859, D860, D861, D862, D863, D864, D865, D866, D867, D868, D869, D870, D871, D872, D873, D874, D875, D876, D877, D878, D879, D880, D881, D882, D883, D884, D885, D886, D887, D888, D889, D890, D891, D892, D893, D894, D895, D896, D897, D898, D899, D900, D901, D902, D903, D904, D905, D906, D907, D908, D909, D910, D911, D912, D913, D914, D915, D916, D917, D918, D919, D920, D921, D922, D923, D924, D925, D926, D927, D928, D929, D930, D931, D932, D933, D934, D935, D936, D937, D938, D939, D940, D941, D942, D943, D944, D945, D946, D947, D948, D949, D950, D951, D952, D953, D954, D955, D956, D957, D958, D959, D960, D961, D962, D963, D964, D965, D966, D967, D968, D969, D970, D971, D972, D973, D974, D975, D976, D977, D978, D979, D980, D981, D982, D983, D984, D985, D986, D987, D988, D989, D990, D991, D992, D993, D994, D995, D996, D997, D998, D999, D1000
				1S2471	D613-D616, D617, D618, D619, D707
				1S1554	D701, D702, D705, D709

AF Assembly (GWK-228)

SEMICONDUCTORS

Mark	Part No.	Symbol & Description
	2SK129A	Q501, Q502
	2SC2291	Q503, Q504
	2SC2259	Q505, Q506
	2SC2705/A/- O	Q519-Q522
	(2SC2705/A/-Y)	
	2SA1145/A/- O	Q509, Q510, Q527, Q528
	(2SA1145/A/-Y)	

CAPACITORS

Mark	Part No.	Symbol & Description
	ACH-260	C403, C404 Electrolytic (10000/80)
	ACH-259	C405, C406 Electrolytic (8200/56)
	ACG-019	C401, C402 Ceramic
	CQSA 470J 50	C501, C502
	CQSA 121J 50	C507, C508
	CQSA 681J 50	C503, C504
	CEANP R47M 50	C701, C702
	CEANP 330M 25	C513, C514
	CEA R22M 50L	C705, C706
	CEA 2R2M 100L	C710
	CEA 220M 25L	C409, C410
	CEA 470M 25L	C411, C412, C415
	CEA 470M 50L	C413, C418
	CEA 101M 25L	C416, C709
	CEA 101M 35L	C505, C506, C511, C512
	CEA 471M 6L	C707
	CCDSL 050C 50	C509, C510
	CCDSL 820K 500	C515, C516, C519, C520
	CCDSL 820J 50	C609-C612
	CKDYB 331K 50	C617-C620
	CKDYB 102K 50	C407, C408, C414, C708
	CKDYB 122K 50	C621, C622
	CKDYF 103Z 50	C711, C712, C623, C624
	CKDYF 472Z 50	C601, C602, C603, C604
	CKDYF 473Z 50	C417, C605-C608, C613-C616
	CQMA 682K 50	C517, C518
	CQMA 473K 50	C703, C704

RESISTORS

Note: When ordering resistors, convert the resistance value into code form, and then rewrite the part no. as before.

Mark	Part No.	Symbol & Description
	ACN-139	R591, R592 Wire wound (0.33/5WX2)
	RD½ PMFL □□□ J	R585, R586
	RD½ PMF □□□ J	R401, R402, R405, R406, R408, R525-R528, R547, R548, R553, R554, R561, R562, R565, R566, R587-R590, R601-R604, R701, R702, R705-R708
	RD½ PS □□□ J	R637-R640, R659-R662
	RFA½ PS □□□ J	R549-R552, R563, R564, R567, R568, R571, R572, R577, R578
	RD½ PM □□□ J	Other resistors

OTHERS

Mark	Part No.	Symbol & Description
	AKB-094	Terminal
	AKB-095	Terminal
	ASR-107	RL701 Relay
	ABA-258	Screw
	BBZ30P080FZK	Screw (3x8)
	PBZ30P60FMC	Screw (3x6)
	AEC-818	Mica wafer

Headphone Jack Assembly

Mark	Part No.	Symbol & Description
	AKN-045	Phone jack

Switch Assembly

Mark	Part No.	Symbol & Description
	SUL6MYBXSFC	S301 Push switch
	RD½ PS821J	R301, R307, R303, R304

Terminal Assembly

Mark	Part No.	Symbol & Description
	AKB-093	Terminal
	RS1L331J	R319, R320

Equalizer Amp. Assembly (AWF-059)

SEMICONDUCTORS

Mark	Part No.	Symbol & Description
	2SK129A	Q801, Q802
	2SC2291	Q803, Q804
	NJM4558DXC	Q807, Q808
	2SA970	Q805, Q806
	US1035	D801, D802
	(1S1555)	

CAPACITORS

Mark	Part No.	Symbol & Description
	CQSA 331J 50	C801, C802
	CQSA 821J 50	C803, C804
	CEANP 220M 25	C811, C812
	ACE-078	C807, C808, Mylar (0.018)
	ACE-079	C805, C806 Mylar (0.068)
	ACE-086	C809, C810 Mylar (1200p)
	ACE-093	C813, C814 Mylar (3900p)
	CEA 220M 25L	C815

RESISTORS

Note: When ordering resistors, convert the resistance value into code form, and then rewrite the part no. as before.

Mark	Part No.	Symbol & Description
	RD¼ PM □□□ J	R801-R836

OTHERS

Mark	Part No.	Symbol & Description
	AKB-098	Terminal (White)
	AKB-099	Terminal (Red)

Control Assembly (AWG-090)

SEMICONDUCTORS

Mark	Part No.	Symbol & Description
	AEL-370	D1-D5 LED (Green)
	AEL-369	D6 LED (Orange)
	MZ-061	D7

SWITCHES

Mark	Part No.	Symbol & Description
	ASG-812	S1 Push switch (FUNCTION)
	SEAV4S	S2 Push switch (AUX 1/2)
	SEA8V2B1B4S	S3 Push switch (LOUDNESS, ADAPTOR/TAPE2)

CAPACITORS

Mark	Part No.	Symbol & Description
	CQMLA 683K 50	C103, C104
	CQMLA 224K 50	C1, C2
	CQSA 150J 50	C105, C106
	CQSA 221J 50	C3, C4
	CQMLA 103K 50	C109, C110
	CQMLA 223K 50	C101, C102
	CQMLA 563K 50	C5, C6
	CQMA 102K 50	C107, C108
	CEA 100M 50L	C111, C112

RESISTORS

Note: When ordering resistors, convert the resistance value into code form, and then rewrite the part no. as before.

Mark	Part No.	Symbol & Description
★	ACT-170	VR1 Variable resistor (250k, BALANCE)
★	ACT-171	VR2 Variable resistor (100k, VOLUME)
★	ACT-169	VR3 Variable resistor (100k, BASS)
★	ACT-168	VR4 Variable resistor (100k, TREBLE)
	RD1/4PM □□□ J	Other resistors

9. PACKING

Mark	No.	Part No.	Description
	1.	ARB-543	Operating instructions
	2.	AHE-214	Packing case
	3.	AHE-340	Front rear pad

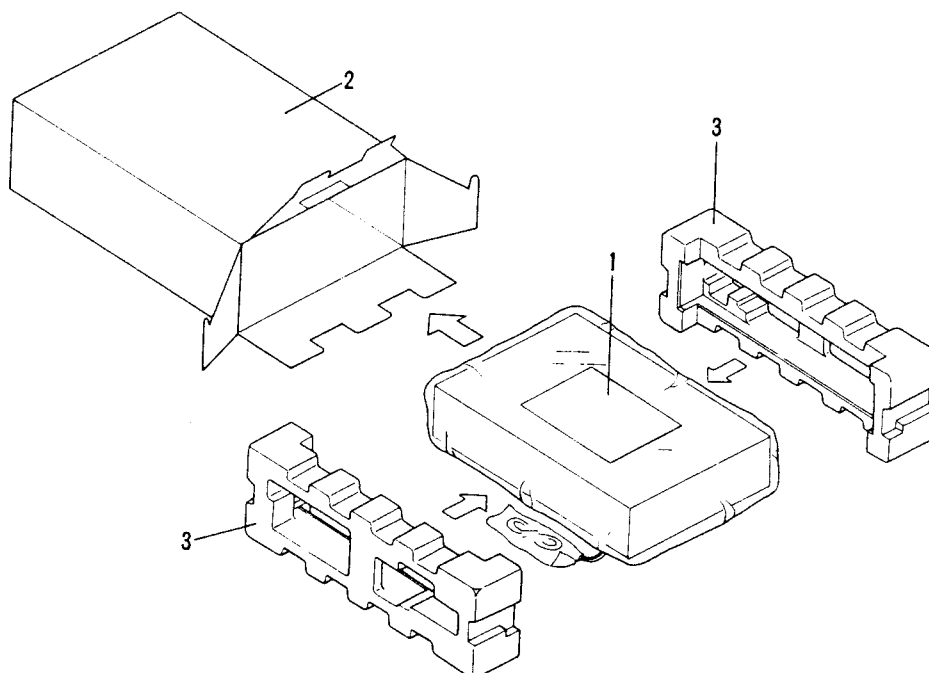

10. SAFETY INFORMATION

1. SAFETY PRECAUTIONS

The following check should be performed for the continued protection of the customer and service technician.

LEAKAGE CURRENT CHECK

Measure leakage current to a known earth ground (water pipe, conduit, etc.) by connecting a leakage current tester such as Simpson Model 229-2 or equivalent between the earth ground and all exposed metal parts of the appliance (input/output terminals, screwheads, metal overlays, control shaft, etc.). Plug the AC line cord of the appliance directly into a 120V AC 60Hz outlet and turn the AC power switch on. Any current measured must not exceed 0.5mA.

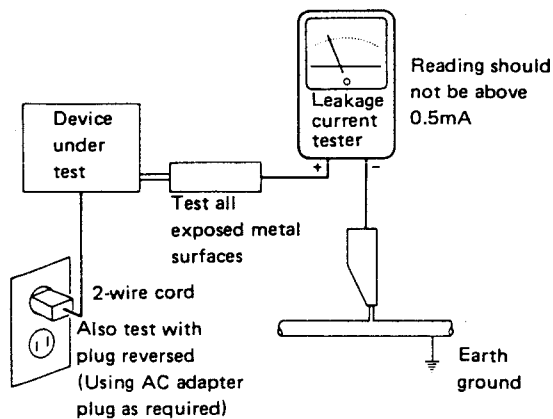

AC Leakage Test

ANY MEASUREMENTS NOT WITHIN THE LIMITS OUTLINED ABOVE ARE INDICATIVE OF A POTENTIAL SHOCK HAZARD AND MUST BE CORRECTED BEFORE RETURNING THE APPLIANCE TO THE CUSTOMER.

2. PRODUCT SAFETY NOTICE

Many electrical and mechanical parts in the appliance have special safety related characteristics. These are often not evident from visual inspection nor the protection afforded by them necessarily can be obtained by using replacement components rated for voltage, wattage, etc. Replacement parts which have these special safety characteristics are identified in this Service Manual.

Electrical components having such features are identified by marking with a Δ on the schematics and on the parts list in this Service Manual.

The use of a substitute replacement component which does not have the same safety characteristics as the PIONEER recommended replacement one, shown in the parts list in this Service Manual, may create shock, fire, or other hazards.

Product Safety is continuously under review and new instructions are issued from time to time. For the latest information, always consult the current PIONEER Service Manual. A subscription to, or additional copies of, PIONEER Service Manual may be obtained at a nominal charge from PIONEER.

11. FOR S AND S/G TYPES

The S and S/G types are the same as the KU type with the exception of the following sections.

Contrast of Miscellaneous Parts

Mark	Symbol & Description	Part No.			Remarks
		KU type	S type	S/G type	
⚠ ★	T1 Power transformer (120V) (110V, 120V, 220V, 240V)	ATS-013	
⚠ ★★	FU1 Fuse (6.3A)	AEK-309	ATS-030	
⚠ ★★	FU2 Fuse (3.15A)	AEK-124	
⚠	S2 Line voltage selector	AEK-124	AEK-124	
⚠	C1 Capacitor (0.01)	ACG-502	ACG-001	AKX-063	
⚠	C2 Capacitor (0.22)	ACE-214	ACE-215	ACG-502	
⚠	AC power cord	ADG-073	ADG-060	ACE-215	
	Operating instructions (English)	ARB-543	ARB-543	ADG-060	
	(Spanish)	ARC-049	ARB-543	
	Packing case	AHE-214	AHE-227	ARB-543	

Schematic Diagram

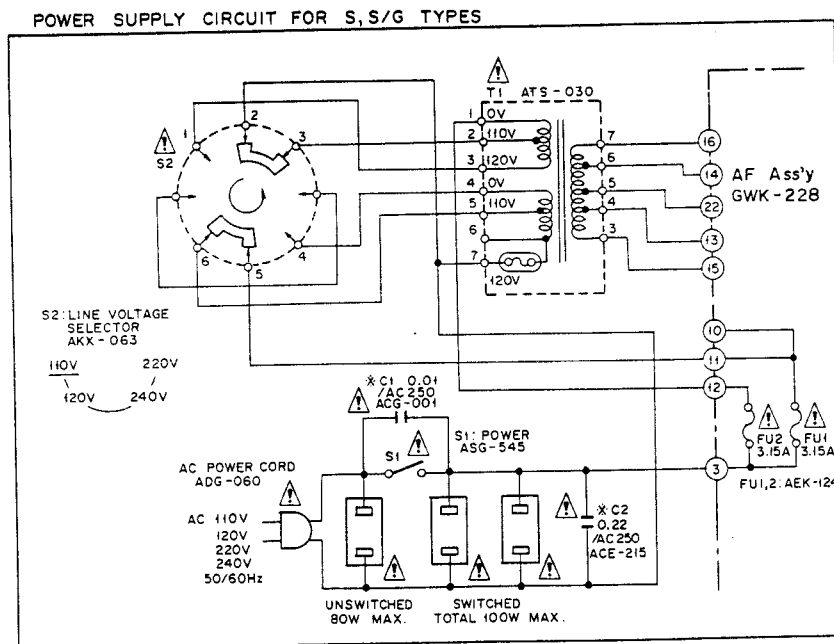

12. FOR YP TYPE

The YP type is the same as the KU type with the exception of the following sections.

Contrast of Miscellaneous Parts

Mark	Symbol & Description	Part No.		Remarks
		KU type	YP type	
⚠ ★	T1 Power transformer (120V) (240V)	ATS-013	
		ATS-027	
⚠ ★★	FU1 Fuse (6.3A) (T3.15A)	AEK-309	
		AEK-042	
⚠	C1 Capacitor (0.01)	ACG-501	ACG-001	
⚠	C2 Capacitor (0.22)	ACE-214	ACE-215	
⚠	AC socket (AC OUTLETS)	AKP-501	
⚠	AC power cord	ADG-073	ADG-064	
	Packing case	AHE-214	AHE-227	

Schematic Diagram

POWER SUPPLY CIRCUIT FOR YP TYPE

